

# Density of Matter

## Instructional Objectives

After viewing the program and participating in the follow-up activities, the student will be able to:

1. state the distinctions among mass, volume, and density,
2. describe a process to measure density of an object as compared to water, and
3. explain the role of density in slowing the expansion of the universe.

## Synopsis

This program demonstrates two ways to compare the densities of different substances, direct and indirect comparison. Students observe the same substance, water, compared to itself at different temperatures. Then water and salt water are compared indirectly through their effects on a slice of carrot. The role of density of matter in space is discussed in relationship to the concept of the expanding universe. Within the program, the definitions of mass, volume and density are reviewed.

The Director of the Space Telescope Science Institute, Dr. Riccardo Giacconi, is interviewed in "The People Behind the HST." This interview allows students an opportunity to get to know the person heading the scientific efforts of the Space Telescope Science Institute.

Dr. Eric Chaisson brings us the latest information from the HST Data Stream.

## Vocabulary

*Cubic Centimeter* - A unit frequently used as a measure of volume (see diagram).

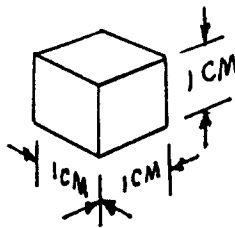

*Density* - The ratio of the mass of an object to its volume. For liquids and solids, as volume increases, mass increases, thereby maintaining a constant ratio.

*Mean Density* - The mean density of the universe, which would be the universal density if the atoms of all of the stars and galaxies could be scattered about with complete uniformity.

*Property* - Any of the qualities or characteristics that together make up the nature or basic structure of a substance.

*Specific Density* - The mass of a substance compared to an equal volume of water.

*Specific Gravity* - The ratio between the density of a substance and the density of water.



*Volume* - Space occupied in three dimensions by a substance. Measured by height x length x width for a rectangular shape; height x radius x radius x pi for a cylindrical shape; radius x radius x radius x pi for a spherical shape.

## Previewing

Ask students to recall as many topics or images as they can that have been discussed by Dr. Eric Chaisson throughout the series. Ask students to identify the scientific discoveries made through the Hubble Space Telescope thus far.

Bring in a variety of objects. Give each pair of students a couple of objects. Ask the students to describe the fundamental features or nature of each object. Use these features to lead into a discussion of fundamental properties.

Set up a tub of water. Bring in a set of objects, some that will suspend in water, others that will float, and some that will sink. Ask the students to conjecture as to why different substances behave differently when placed in water.

Bring in several objects such as a brick, a tin can, and a small ball. Ask the students to state the formula for the volume of each object. If this is new concept, work with the students to derive the formula from a current level of understanding.

Bring in an ice cube tray with colored ice cubes and a transparent glass. Ask the students to predict what will happen when with the ice cube is added to a glass of water. Record their predictions on the board. Place the ice cube in the water and ask students to describe what they observe. Did observation match prediction?

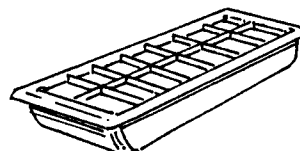

## Postviewing

Have the students replicate the density experiment using a carrot that is demonstrated in the video. They will need a container such as a glass, water, salt, a carrot, and a knife. Have the student cut two pieces of carrot of two different lengths. Have them place each piece in water, one at a time. Record observations. Then place the smaller carrot in water and slowly add salt. Stir after each addition of salt so that it dissolves. What happens to the carrot?

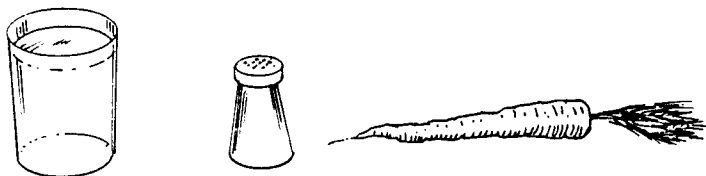

Discuss with the students the latest information from the Hubble Space Telescope. Also take a few minutes to discuss the career piece. Ask the class to make a list of all the skills discussed in the career pieces to date. Discuss why all people need to be science literate in today's technological society.

Have students record mass and dimensions of several objects, then calculate volume and density. Students should measure both regular and irregular objects. Review geometric principles as necessary.

## Active Involvement

Students can observe and compare different densities by making a wave machine. The students will need a plastic bottle with screw cap, rubbing alcohol, food coloring and paint thinner. Have the students wash out the bottle. Fill the bottle one-third of the way with rubbing alcohol. Add food coloring and shake the bottle until the alcohol takes on an even color (see diagram). Then add enough paint thinner to fill the bottle. Allow no air to be in the bottle. Have the students experiment with motions of the bottle and record what they observe. (Have students use caution; these materials are flammable.)

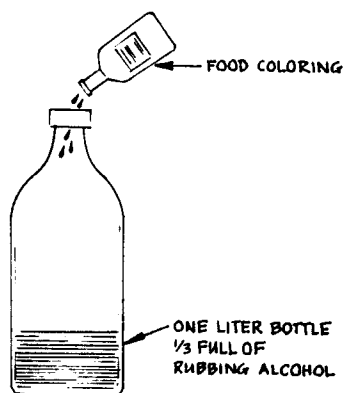

## Bibliography

*For high school readers:*

Asimov, Isaac. *The Collapsing Universe*. New York: Walker and Co., 1977.

Waldrop, Mitchell. "The Universe in Depth." *Science*, Vol. 234, December 5, 1986, p. 1202.

*For middle school readers:*

Gardner, Robert. *Ideas For Science Projects*. New York: Franklin Watts, 1986.

Jollands, David (Ed.). *Measuring and Computing*. New York: Arco Publishing, Inc., 1986.

# See for Yourself: Experiments/Projects

## Density and Movement

Movement can be influenced by density. Examples can be seen in weather patterns and ocean currents. This experiment will allow you to explore the relationship between density and movement.

### ► MATERIALS:

- ½ teaspoon measure
- thermometer
- test tube or cup
- salt
- small aquarium tank
- ice cubes made with food coloring
- colored pencils (to match color of ice cubes)

### ► PREPARATION:

Mix water and food coloring until the color is very intense. Pour into an ice cube tray. Freeze.

### ► DIRECTIONS:

#### Part I

Fill an aquarium tank with lukewarm water. Place the thermometer in the tank. Wait until the water temperature is the same or nearly the same as the room temperature. Gently place the colored ice cubes along the edge of the aquarium (see diagram). Record your observations in drawings and with words.

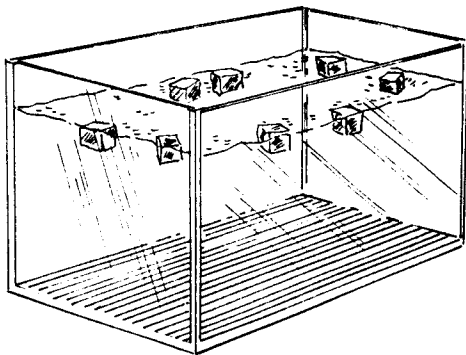

Wait five minutes and observe the water again. What is happening? Record your observations. Continue this process until you have an understanding of what is happening in the fish tank.

What does the water look like when the ice cubes have melted completely? Record your observations.

Write your conclusions as to the relationship between density and movement.



#### Part II

Empty the aquarium tank and refill with water. Again, let the aquarium return to room temperature.

Fill a single test tube three-quarters full with luke-warm tap water. Add eight drops of food coloring (not yellow) to the test tube. Now add ½ teaspoon of salt. Mix the contents of the test tube. Gently pour colored salt water into the tank (see diagram). Record your immediate observations in drawings and words.

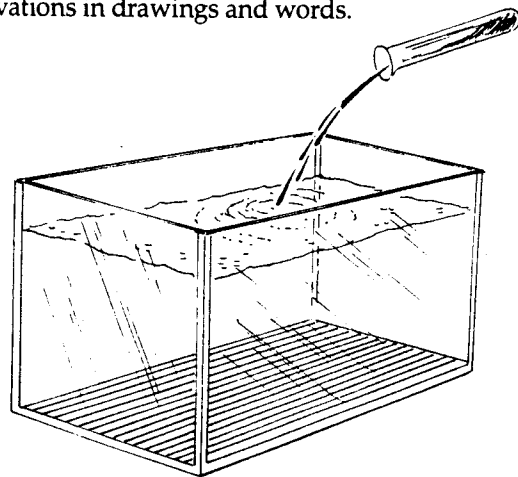

Wait five minutes. Record observations again. Repeat. Explain what happened?

How did part I and part II of this experiment differ in terms of densities of the substances? Explain the differences in the outcomes.

Where on earth do we have conditions similar to those in part II? Why do scientists consider the balance of nature so critical in these areas?

## Life Jackets

### ► MATERIALS:

- styrofoam pieces of 9" x 9" or greater
- swimming pool
- willing volunteer(s) to get in the pool

### ► PREPARATION:

Have one or more students in swimsuits. (Be sure the volunteers are able swimmers.)

### ► DIRECTIONS:

Go to the end of the pool where the water is just over the head of the swimmer. Ask the swimmer to stand on the bottom of the pool and relax for a few seconds. Record observations.

When the swimmer comes up, provide him/her with a piece of styrofoam. Ask the swimmer to stand on the bottom and then to relax. Does the swimmer move? Record observations.

Continue to give more styrofoam to the swimmer to hold and repeat the step above.

What is happening to the density of the swimmer when her/his possessions are included in the overall density of the swimmer? Remember that density is equal to mass divided by volume.

How do life jackets work? Are life jackets one-size-fit all? Why or why not?

## Submarine Movements

### ► MATERIALS:

- wide-necked bottles that are smaller than tank or tub
- pebbles or rocks to fit through bottle neck
- aquarium tank or large tub of water.

### ► DIRECTIONS:

1. Fill the bottle with water and place it in the tub. Record your observation.
2. Empty the water out of the bottle, put the cap on and place it in the tub. Record your observation.
3. Place a pebble in the bottle, put the cap on and place it in the tub. Record your observation.
4. Repeat step 3 several times.
5. Add one cup of water to the bottle, put the cap on and place it in the tub. Record your observation.

6. Repeat step 5 several times.

7. A submarine has ballast tanks which may take water or be pumped out of water. Explain how a submarine can raise or lower itself in the water based on your experimental results.

## Using a Hydrometer

Specific gravity is the ratio between the density of a substance and the density of water. Specific gravity is often used to describe liquids. A hydrometer measures specific gravity. The hydrometer is floated in a liquid. It floats high in a dense liquid and low in a less dense liquid. The specific gravity can be determined by reading the mark on the surface of the liquid.

### ► MATERIALS:

- soft drink
- tomato juice
- vegetable oil
- water
- salt
- molasses
- hydrometer

### ► DIRECTIONS:

Design a chart to record a reading of the hydrometer for each liquid you have.

Mix the salt with the water to make salt water.

Using a hydrometer, measure the specific gravity of each substance. Record.

Create a graph comparing the specific gravity of each substance.

Challenge: What are the units for specific gravity? Hint: Refer to the definition for specific gravity and plug in the units of measurements for the numerator and denominator. Cancel out units that are identical.

# Career Profile

**Riccardo Giacconi**

Director

Space Telescope Science Institute

Education: Ph.D Physics, University of Milan



Who would have thought that a young boy growing up in Italy at the time of World War II would become the Director of the Space Telescope Science Institute in Baltimore, Maryland? Riccardo Giacconi has done just that.

Riccardo went to the university in Milan, Italy, where all citizens are provided with a free college education. He did not stop after four years, but continued with his schooling until he had completed his Ph.D. in physics, and then turned right around to teach physics at the same university. After two years, Riccardo moved to the United States and began an impressive career of research, writing, and scientific discovery.

Riccardo's primary field of interest involves X-ray astronomy. In fact, he was in charge of the first group of scientists who made observations using the X-ray part of the spectrum. Riccardo has been the Principal Investigator on several NASA programs. His groups have obtained the first solar X-ray picture, and detected the first extrasolar X-ray source. He has written more than 150 scientific books and articles. Not surprisingly, his newest book, of which he is a co-author, is called *The X-Ray Universe*.

## **Chief Responsibilities**

As Director of the Space Telescope Science Institute, Riccardo Giacconi's primary responsibility is to manage an organization that can serve as a tool for astronomers from all over the world. The Science Institute is a new type of institution for NASA. Never before has there been one facility that would be the connecting point for scientists, universities, and the world wide astronomical community.

Riccardo's decisions will influence the course of space astronomy for many years to come. He must personally approve all observations that are to be carried out with the HST. While setting the scientific priorities for HST, Riccardo seeks out the advice of various committees involved in the HST project, as well as the views of other members of the worldwide astronomy community. He must make sure that the very best science possible will be accomplished with the Hubble Space Telescope. This is carried out through a democratic and intellectually demanding peer review process.

One of the main areas of focus for those at the Space Telescope Science Institute has been education. Riccardo and others at the Science Institute have invested a great deal of time speaking to students, the press, and the general public. Riccardo is deeply committed to science education. He emphasizes the need to teach the process of science, in addition to sharing the fruits of discovery.

Riccardo feels that it is the scientists' responsibility to share with the general public what it is that they are discovering about the universe, how the universe came about, and how it is evolving. Because technical education is such a problem in society today, those at the Science Institute feel that they should do their part to help get people interested in science. They publish books, offer lectures, provide advanced individual studies, and work in the public schools. Riccardo encourages people who work at the Institute to get involved in these activities.

## **A Typical Day**

Riccardo must travel a great deal in his job. However, when he is at work in Baltimore, Maryland, he has a number of things that must get done. He must deal with his mail and conduct and attend meetings to discuss issues with other scientists and engineers. "What do we have to do," "how can we go about doing it," "what are the problems," are all typical questions that must be addressed.

Because he is a scientist who researches and publishes papers on astronomy, Riccardo needs time to himself to read and write. He thinks that it is important for the Director to be a working scientist so that he does not forget the purposes of the HST mission. Unfortunately, he finds he is not able to leave his work at the office. When at home, or even out in his garden, he finds himself thinking about his work.

Riccardo frequently travels around the country and the world. He may appear as a spokesperson for the Hubble Space Telescope or the Space Telescope Science Institute, or he may travel to a conference purely as a scientist. Recently, he has gone to Italy to provide information on the HST and to the Soviet Union to give lectures. He is working on some joint experiments with scientists in Milan, Italy and in Munich, Germany. He will soon be involved in evaluating the reunification of German science institutes that came about from the reunification of the East and West German governments. Riccardo notes that scientists must work closely, share information and develop theories together. While doing these tasks, they also form an important community of friendships.

## Career Viewpoint

Riccardo suggests that when planning their future careers, students decide what it is they are especially interested in, what they enjoy learning about, and what they enjoy doing. Whatever their career, it will probably take up at least eight hours of each day. Therefore, it is important that they start to discover what it is that they like to do, and then do it. Although earning money in a job is important, it is more important that one be happy.

## Content Consultants for Starfinder- Program 18

Eric Chaisson  
Space Telescope Science Institute  
Operated by AURA for NASA

EllaJay Parfit  
South East Middle School  
Baltimore, MD

Richard Sweetsir  
Stanton College Prep  
Jacksonville, FL

Russ Wright  
Montgomery County Public Schools  
Rockville, MD

## Teacher's Guide

Writers	Graphic Design
Barbara Bourne	Bob Lindler
Pat Murphy	The Design Co-op
Editor	Typesetting
Kate Harrison	Blue Heron Typesetters
Illustrator	
Robert Jones	
Logo Design	
Dave Weaver	

A production of



MARYLAND STATE DEPARTMENT OF EDUCATION  
MARYLAND INSTRUCTIONAL TECHNOLOGY • INTEC

11767 Bonita Avenue  
Owings Mills, Maryland 21117  
(301) 356-5600

Major funding provided by

**MARTIN MARIETTA**

and  
U.S. Department of Education

Office of Educational Research and Improvement  
Fund for the Improvement and Reform of Schools  
and Teaching

Dwight D. Eisenhower National Mathematics and  
Science Program

## Maryland State Board of Education

Robert C. Embry, <i>Pres.</i>	John C. Sprague, <i>Vice Pres.</i>
Herbert Fincher	Elmer B. Kaelin
Donald P. Hutchinson	Joan Maynard
Dr. Joseph L. Shilling	Wilson H. Parran
<i>Secretary-Treasurer of the Board</i>	Benjamin Swinson
<i>State Superintendent of Schools</i>	Edmonia T. Yates
	Vacancy
	Vacancy
	Heather White (Student Member)

Bonnie S. Copeland  
*Deputy State Superintendent  
of Schools*

Francis A. Windsor  
*Assistant State Superintendent in  
Instructional Technology*

William Donald Schaefer, *Governor*

©1990, Maryland INTEC, Maryland State Department of Education

The Maryland State Department of Education does not discriminate on the basis of race, color, sex, age, national origin, religion, or handicapping condition in matters affecting employment or in providing access to programs.